



ECLYPSE™ Connected System Controller



Overview

The ECLYPSE Connected System Controller (ECY-CSC) is a modular and scalable platform used to control a wide range of HVAC applications. It supports multi-protocol communications, including BACnet/IP, and is a listed BACnet Building Controller (B-BC).

The ECY-CSC consists of a control, automation and connectivity server, power supply, and I/O extension modules.

This programmable controller provides advanced functionality, such as customizable control logic, Web-based design and visualization interface (ENVYISION embedded), logging, alarming, and scheduling.

Applications

The ECY-CSC is typically used as:

- A controller for medium/large sized Air Handling Units (AHU), central plant, lighting, power monitoring, and other applications.
- Small building server and equipment controller with embedded ENVYISION. For example, it can be used to control and serve a boiler room.

Features & Benefits

Connectivity

The different types of connections supported by the ECY-CSC are as follows:

IP wired connection

Internal switch with two Ethernet ports allows the controllers to be wired in a star or daisy-chain topology. With a daisy-chain topology:

- Fewer wire runs to a centralized switch are required, thereby achieving installation and cost reduction.
- A laptop can be connected to the second Ethernet port for direct programming, configuration, and commissioning using EC-gfxProgram or ENVYISION.

IP wireless (Wi-Fi) connection

- Wi-Fi Client - Connection to the building's existing Wi-Fi network or to another controller's Wi-Fi Hotspot or Access Point.
- Wi-Fi Access Point - extending the building's wired IP network to your Wi-Fi Client devices.

- Wi-Fi Hotspot - your own wireless area network, for wireless communication between the controllers, or with a mobile device or laptop for configuration, commissioning and servicing.

Both IP wired and wireless (Wi-Fi) connection

The availability of both Ethernet ports and USB ports for the Wi-Fi Adapter, allows for simultaneous wired IP and Wi-Fi communication on the same controller, which means you can choose and combine these connection methods. For example, Wi-Fi can be used between two controllers to jump a large atrium.

Connect from anywhere

Control technicians, facility managers, occupants, and others can easily connect to the system, on-site or off-site, using the different available tools:

- ENVYSION to create and view the graphical interface
- EC-*gfx*Program to create custom control sequences
- *myDC* Control to view, edit, and configure system operating parameters

IP Communication

- Increased speed and improved handling of numerous trend logs that enable applications, such as advanced analytics that require a large amount of data.
- Experience faster response and save time when programming, configuring, creating and viewing graphics, and upgrading your system.
- Control technicians can connect the ECLYPSE Wi-Fi Adapter to the ECY-CSC thereby creating a Wi-Fi Hotspot network. The control technician can then connect wirelessly to the system using a mobile device or laptop, for faster, easier system configuration, programming, commissioning, and servicing.
- Hostname management allows the controller to be addressed by a nickname to facilitate network management.

Open to Web Services

With the RESTful API, the ECY-CSC's data can be accessed from different applications, such as energy dashboards, analytics tools, and mobile applications. The RESTful API documentation explains the implementation protocol for this interface.

HTML5 Visual Interface

The ECY-CSC comes embedded with both ENVYSION Studio and Viewer, and xpressENVYSION.

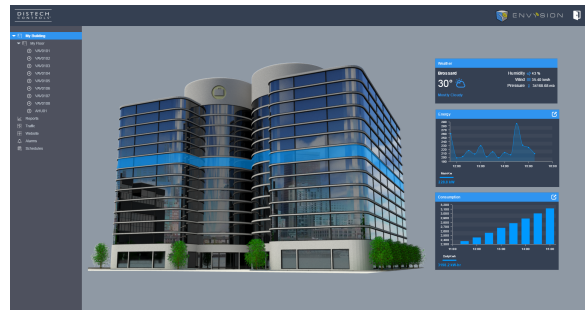

ENVYSION – Web-based graphic design and visualization interface

ENVYSION is a web-based graphic design and visualization interface used to create and deliver interactive graphical user interfaces and an optimal user experience for building owners and facility managers to better manage facility data.

Programmability

Supports Distech Controls' EC-*gfx*Program, which makes Building Automation System (BAS) programming effortless, by allowing you to visually assemble building blocks to create a custom control sequence for any HVAC, lighting, or building automation application.

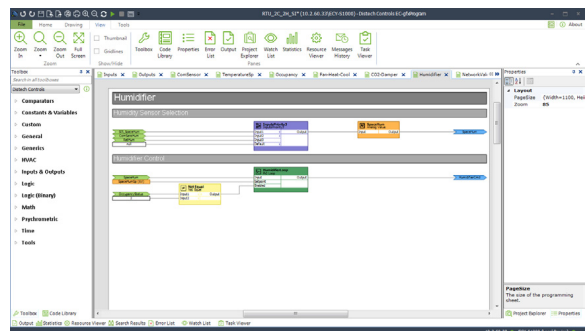

Batch EC-*gfx*Program Projects and Firmware Download

EC-*gfx*Program projects can be downloaded in batch to multiple controllers, for greater time savings. Batch firmware update can also be performed on multiple controllers.

Simplified Network Commissioning

The XpressNetwork Utility saves you time and expense by giving you increased control over multiple ECLYPSE controllers through device discovery and batch operations such as configuring, programming, and updating multiple ECLYPSE controllers on the network.

In addition, with the embedded step by step Commissioning Wizard, all configuration operations can be setup and applied in one go.

Increase productivity using the *xpressNetwork* Companion mobile app, making it easier to identify and locate a controller on the network. Use the QR Code marked on ECLYPSE controllers to easily collect key controller data and to facilitate its network integration with *xpressNetwork* Utility.

Scalable and Modular

The ECY-CSC is sized to cost-effectively meet the requirements of any HVAC application from small to medium to large systems. The most capable Connected System Controller model can be expanded to support up to 20 input/output (I/O) modules (up to 320 I/Os) while being able to adapt to new requirements as the need arises.

A connecting cable is used to connect successive rows of modules within a controls' cabinet to provide power and communication.

ECY-RS485 communication module

An ECY-RS485 communication module adds two extra RS-485 trunks to support more BACnet MS/TP and Modbus RTU devices.

ECY-MBUS communication module

An ECY-MBUS communication module has one M-Bus port for meter integration, thus eliminating the need for a third-party gateway (from M-Bus to BACnet/IP).

BACnet/IP Device (pending)

The ECY-CSC is BTL-listed as a BACnet Building Controller (B-BC) and is certified WSP B-BC (Europe) and AMEV AS-A & AS-B (German-speaking countries). It supports BACnet/IP for faster communication in comparison to the traditional twisted pair communication bus.

Multi-Protocol Support

The ECY-CSC supports a range of communication protocols such as BACnet MS/TP, Modbus RTU, and Modbus TCP.

BACnet MS/TP and Modbus RTU communications are made by connecting directly to separate RS-485 ports. The ECY-CSC integrates up to three RS-485 ports when equipped with one ECY-RS485 extension module allowing the controller to support more than one trunk or communication protocol at a time.

MS/TP to IP routing

ECLYPSE™ Connected System Controller

Integrate full MS/TP trunks into a supervisory system like the EC-Net^{AX} Supervisor, without the need for other hardware components such as an external BACnet MS/TP to IP router.

Modbus RTU and TCP

Modbus RTU and TCP communication can be used to integrate a wide variety of Modbus devices such as power and water meters, Variable Frequency Drives, air flow sensors, and more, without the need for additional hardware such as a gateway.

FIPS 140-2 Level 1 Compliant

FIPS 140-2 Level 1 compliance provides an enhanced level of security to protect data the controller is collecting and sharing making it suitable for use in the most sensitive environments.

Weather Forecast

The weather forecast is directly available from the internet to be shown on a connected ECx-Display or to be used by the controller's code.

Smart Room Control Support

The Smart Room Control solution is an end-to-end system for the control of HVAC equipment, lighting, and shades/sunblinds, achieving the highest levels of comfort for occupants while cutting costs from installation time and wiring/material requirements to energy consumption. This solution combines:

- Lighting and shade/sunblind expansion modules to control lights (on/off or dimming) and shades/sunblinds (up/down and angle rotation).
- Multi-sensor combining motion and luminosity (Lux) sensors and an Infrared receiver that works with a convenient remote control.
- The ECLYPSE platform is compatible with Distech Controls line of *Bluetooth*® low energy technology enabled devices (Allure UNITOUCH™ and EC-Multi-Sensor-BLE) and mobile application providing state-of-the-art occupant management.
- Allure™ Series Communicating room sensors for increased occupant comfort settings using integrated sensors for temperature, humidity, CO₂, and motion.

Allure™ Series Communicating Sensor Support

These controllers work with a wide range of sensors, such as the Allure Series Communicating Sensors that are designed to provide intelligent sensing and control devices for increased user experience and energy efficiency.

- Allure EC-Smart-View
- Allure EC-Smart-Comfort
- Allure EC-Smart-Air
- Allure UNITOUCH



Mobility

The controller can be remotely accessed to program, configure, or maintain the installation thus reducing costs associated with on-site visits. Through a mobile device or PC, a range of tasks can be performed using the following free-to-use tools and interfaces:

- ENVYISION web-based graphic design and visualization interface
- EC-*gfx*Program graphical programming interface
- myDC* Control mobile application

Hand/Off/Auto Switches and Potentiometers

The front assembly of Hand/Off/Auto (HOA) equipped I/O models allow users to override the control outputs for commissioning and maintenance purposes.

Universal outputs have potentiometers providing manual analog signal and output control to override voltage or current signal.

High-Efficiency Design

The power supply uses the latest high-efficiency switch-mode circuitry to make more power available to operate additional modules and for cooler operation.

Hot-Swappable Tool-Less Design and Unique Latching Mechanism

The I/O modules are hot-swappable for replacement without interrupting power and communications to other modules.

The front assembly of I/O modules separate from the wiring base by pushing the two latches up to unlock a module's front assembly and then opening and pulling the hinged gull-wing covers. The latch design locks the front assembly to the wiring base.

The hinged gull-wing design protects and cover the stacked dual row I/O terminal strips.



Ease of Installation

The ECY-CSC modules are plug & play devices. They are equipped with HD-15 connectors that transmits power and communications to the next module for fast and easy assembly.

I/O Status LEDs

The status LEDs on the I/O modules allows the user to confirm the status of the inputs/outputs and facilitate commissioning and troubleshooting.

Auto-Addressing

The auto-addressing feature eliminates the need to manually assign an address to each I/O module therefore reducing installation and configuration time.

Digital Inputs Up to 120Hz

The ECY-16DI module supports pulsed signals up to 120Hz for equipment status monitoring and alarm point monitoring, commonly used in energy metering applications.

Color-Coded, Rising Cage Terminals

Terminal blocks are uniquely identified and color-coded for clarity and to prevent wiring mistakes. The rising cage clamp terminal block connectors offer a more robust and secure wire connection, designed to withstand activity and vibrations.

Robust Protection

The I/O modules are protected against mis-wiring and faults to prevent damage caused by incorrect wiring or other mishaps.

The power supply module contains over-voltage and over-current output protection to protect the electronics in unstable power supply conditions and against mis-wiring.

Alarms, Trend Log, Schedule Support

Embedded alarms, trend log and schedule support allows for fully distributed data and logic providing a more robust system. Embedded trend logs simplify system troubleshooting when compared to a centralized system.

Email Notifications Service

Technicians & facility managers can receive automatic email notifications for system status and alarms to ensure faster system servicing and response time. Email notification text can be customized to provide pertinent information about the issue at hand.

Model Selection

The ECLYPSE Connected System Controller consists of a power supply, a control, automation and connectivity server, I/O extension modules, and communication modules to create a controller tailored to its application. The different models for each are shown in the tables below.

Power Supply

A power supply module must be added after each HD15 cable (see Accessories below).

ECY-PS24	24VAC/VDC power supply module for the ECLYPSE Connected System Controller.
ECY-PS100-240	100 to 240VAC power supply module for the ECLYPSE Connected System Controller.

Control, Automation and Connectivity Servers

Connected System Controller for medium/large sized AHU and plant applications and small building server/controller applications.

Model	With Embedded ENVYISION	Application	Maximum Number of Points Supported	BACnet MS/TP to IP Routing Support – Maximum Number of BACnet MS/TP Devices	Maximum Number of Modbus Devices (RTU or TCP)
ECY-S1000-28		Small size equipment such as a large rooftop unit or a small AHU.	28	No ¹	3
ECY-S1000E-28	■		28	Yes ²	3
ECY-S1000-28-MS			28	Yes ²	3
ECY-S1000E-28-MS	■		28	Yes ²	3
ECY-S1000-48		Medium size equipment such as an AHU or a small size plant room.	48	No ¹	10
ECY-S1000E-48	■		48	Yes ²	10
ECY-S1000-48-MS			48	Yes ²	10
ECY-S1000E-48-MS	■		48	Yes ²	10
ECY-S1000		Large size equipment such as large plant rooms and large data centers.	320 ⁴	Yes ²	96 ³
ECY-S1000E	■				

1. Upgrade and enable the functionality of your ECLYPSE controller's RS-485 ports with our capacity-based upgrade to ECYS1000-48MS.
2. Up to 50 BACnet MS/TP devices recommended on each RS-485 port.
3. Up to 32 Modbus RTU devices recommended on each RS-485 port. The maximum amount of Modbus TCP devices is limited to available system resources (too many devices can affect system performance).
4. The ECY-S1000 models support a maximum of 320 points OR up to a maximum of 20 IO modules.

I/O Modules Selection

	Inputs									Outputs								Basic Power Consumption ² , W		
	Quantity	Digital			Analog					18VDC Power Supply	Quantity	Digital				Analog				
		Contact	Counter	120Hz Pulse Counting	0 to 10VDC	0 to 5VDC	0 to 20mA	Resistance	Thermistor			0-277VAC / 0-30VDC Form-C, 10A	24VAC Triac, 0.5 A	0 or 12VDC	PWM	Floating	0 to 10VDC ¹		0 to 20mA ¹	HOA
ECY-8UI	8	■	■		■	■	■	■	■	■										0.94
ECY-16DI	16	■	■	■																0.94
ECY-6UO											6		■	■	■	■	UO1 UO2 UO3			0.94
ECY-6UO-HOA											6		■	■	■	■	UO1 UO2 UO3	■		0.94
ECY-8DOR											8	■								0.94
ECY-8DOR-HOA											8	■						■		0.94
ECY-4UI4UO	4	■	■		■	■	■	■	■	■	4		■	■	■	■	UO1 UO2 UO3			0.94
ECY-4UI4UO-HOA	4	■	■		■	■	■	■	■	■	4		■	■	■	■	UO1 UO2 UO3	■		0.94
ECY-8UI6UO	8	■	■		■	■	■	■	■	■	6		■	■	■	■	UO1 UO2 UO3			0.94
ECY-8UI6UO-HOA	8	■	■		■	■	■	■	■	■	6		■	■	■	■	UO1 UO2 UO3	■		0.94
ECY-8UI6DOT	8	■	■		■	■	■	■	■	■	6		■		■					0.94
ECY-8UI6DOT-HOA	8	■	■		■	■	■	■	■	■	6		■		■			■		0.94

1. 0 to 10VDC is available on UO1 to UO6. 0 to 20 mA is available on UO1, UO2, and UO3; this option is individually selected through an on-board DIP switch setting.

2. External loads excluded. See the ECLYPSE Selection Tool to calculate the number of Input/Output Extension Modules that can operate with a power supply.

Communication Modules Selection

Communications Module	Description
ECY-RS485	ECLYPSE Communication module with two RS-485 ports for Modbus RTU or BACnet MS/TP.
ECY-MBUS	ECLYPSE Communication module with one M-Bus port, supporting up to 20 M-Bus meters. Upgrade license for the ECY-MBUS communication module to support up to 60 M-Bus meters.

Accessories

ECLYPSE HD15 Cable	6ft (1.8m) cable for Connected System Controller multiple-row panel installations. An HD15 cable must always be followed by a power supply module. For more information, refer to the Hardware Installation Guide.
ECLYPSE Wi-Fi Adapter	Wi-Fi Adapter for ECLYPSE Connected Controllers.

Product Specifications

Power Supply (ECY-PS24)

Power Supply Input

Voltage Range _____ 24VAC/DC; $\pm 15\%$; Class 2

Power Consumption _____ 60VA

Frequency Range _____ 50 to 60Hz

Overcurrent Protection _____ Field replaceable fuse

Fuse Type _____ 4A, fast-acting, 5 × 20mm (GMA-4A)

Power Supply Output

DC Voltage _____ 18VDC regulated

Rated Current Range _____ 0 to 1.6A

Rated Power _____ 30W¹

1. The total power consumption of all modules connected to the right of this power supply, and up to the next connected power supply, including any connected loads, must be less than this value. A separate transformer rated at 60VA minimum and 100VA maximum must be used for each ECY-PS24 power supply for it to operate at full capacity.

Hardware

Power Distribution Direction _____ Powered modules are connected to the right

Backplane Bus _____ Pass-through connection for data and control signals

Status Indicator _____ Green LED: power status

Mechanical

Dimensions (H × W × D) _____ 4.74 × 2.85 × 2.31" (120.31 × 72.38 × 58.56mm)

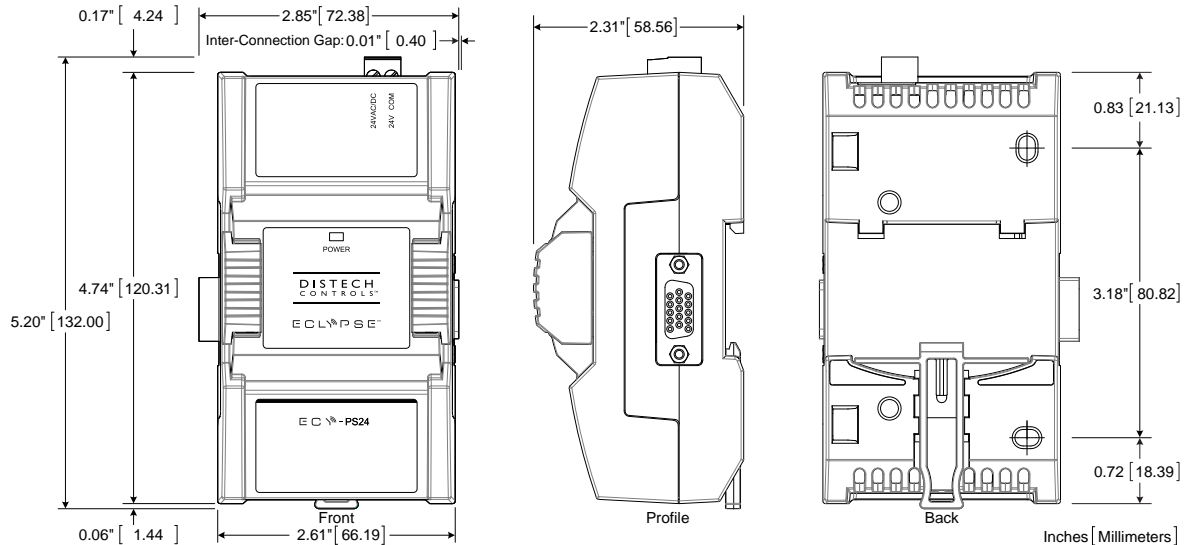

Shipping weight _____ 0.75lbs (0.34kg)

Mounting _____ DIN rail or screw mounting

Enclosure Material¹ _____ FR/ABS

Enclosure Rating _____ Plastic housing, UL94-V0 flammability rating

Plenum rating per UL1995

1. All materials and manufacturing processes comply with the RoHS directive and are marked according to the Waste Electrical and Electronic Equipment (WEEE) directive

Environmental

Operating Temperature _____ 32 to 122°F (0 to 50°C)

Storage Temperature _____ -22 to 158°F (-30 to 70°C)

Relative Humidity _____ 0 to 90% non-condensing

Ingress Protection Rating _____ IP20

Nema Rating _____ 1

Standards and Regulations

CE:

Emission _____ EN61000-6-3: 2007; A1:2011; Generic standards for residential, commercial and light-industrial environments

Immunity _____ EN61000-6-1: 2007; Generic standards for residential, commercial and light-industrial environments

FCC _____ This device complies with FCC rules part 15, subpart B, class B

UL Listed (CDN & US) _____ UL916 Energy management equipment



Power Supply (ECY-PS100-240)

Power Supply Input

Voltage Range _____ 100 to 240 VAC Universal; +10%/-15%

Input Current _____ 400mA typical

Frequency Range _____ 50 to 60Hz

Standby Power consumption _____ <0.5W

Overcurrent Protection _____ Field replaceable fuse

Fuse Type _____ 2.5A, Fast-acting, high-breaking, 250VAC, 5 × 20mm (TF2.5AH250V, IEC60127-2)

Power Supply Output

DC Voltage _____ 18VDC regulated

Rated Current Range _____ 0 to 2A

Rated Power _____ 40W¹

1. The total power consumption of all modules connected to the right of this power supply, and up to the next connected power supply, including any connected loads, must be less than this value.

Hardware

Power Distribution Direction _____ Powered modules are connected to the right

Backplane Bus _____ Pass-through connection for data and control signals

Status Indicator _____ Green LED: power status



Mechanical

Dimensions (H × W × D) ————— 4.74 × 4.08 × 2.31" (120.31 × 103.65 × 58.56mm)

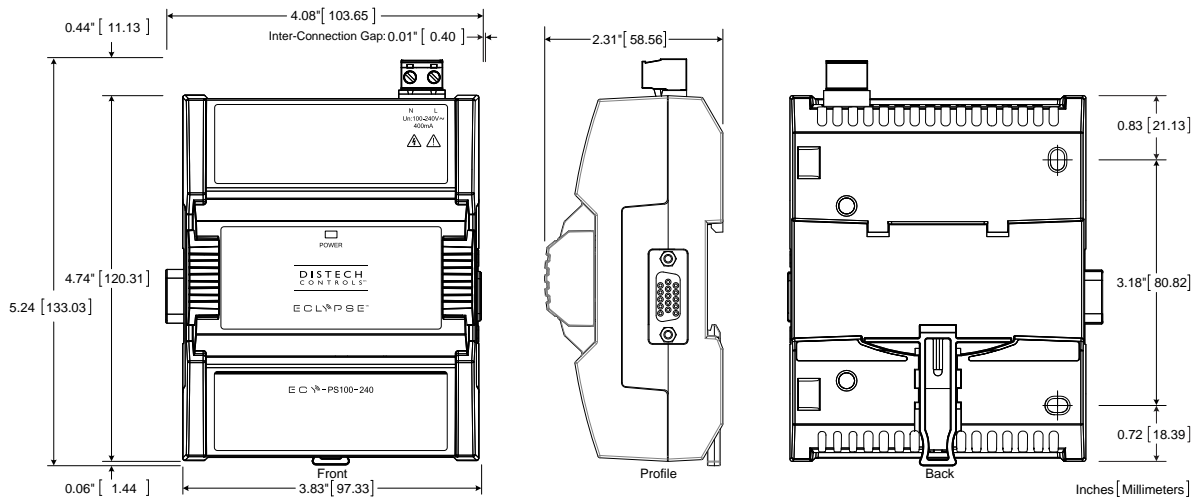

Shipping weight ————— 0.71lbs (0.32kg)

Mounting ————— DIN rail or screw mounting
Refer to Hardware Installation Guide for more information

Enclosure Material¹ ————— FR/ABS

Enclosure Rating ————— Plastic housing, UL94-5VB flammability rating

1. All materials and manufacturing processes comply with the RoHS directive and are marked according to the Waste Electrical and Electronic Equipment (WEEE) directive

Environmental

Operating Temperature ————— 32 to 122°F (0 to 50°C)

Storage Temperature ————— -22 to 158°F (-30 to 70°C)

Relative Humidity ————— 0 to 90% non-condensing

Altitude ————— <6562ft (2000m)

Pollution Degree ————— 2

Ingress Protection Rating ————— IP20

(must be mounted in a protective enclosure to conform with electrical installation standards)

Oversoltage ————— Category II - 2.5 kV

Electrical Protection ————— DC output is Separated Extra-Low Voltage (SELV);
SELV is implemented through reinforced insulation

Standards and Regulations

CE:

- Electrical Safety ————— EN 60730-1 : 2011 - Automatic electrical controls for household and similar use - Part 1: General requirements
- Emission ————— EN61000-6-3: 2007; A1:2011; Generic standards for residential, commercial and light-industrial environments
- Immunity ————— EN61000-6-1: 2007; Generic standards for residential, commercial and light-industrial environments

UL Listed (CDN & US) ————— UL 61010-1 Safety Requirements For Electrical Equipment For Measurement, Control, And Laboratory Use - Part 1: General Requirements - Edition 2 - Revision Date 2008/10/28

FCC ————— This device complies with FCC rules part 15, subpart B, class B



Control, Automation and Connectivity Server (ECY-S1000)

Power Supply Input

Voltage _____ 18VDC

Power Consumption _____ 8.9W; external loads excluded

Communications

Ethernet Connection Speed _____ 10/100 Mbps

Addressing _____ IPv4 or Hostname

BACnet Profile _____ BACnet Building Controller (B-BC)), AMEV AS-A and AS-B (pending)

BACnet Listing _____ BTL, WSP B-BC

BACnet Interconnectivity _____ BBMD forwarding capabilities
BACnet/IP to BACnet MS/TP routing

BACnet Transport Layer _____ IP & MS/TP (optional)

Web Server Protocol _____ HTML5

Web Server Application Interface _____ REST API

Supported BACnet MS/TP and Modbus RTU and TCP Connectivity:

BACnet MS/TP or Modbus RTU _____ 1 × RS-485 serial communications ports
Each RS-485 port supports one communication protocol at a time

RS-485 Wiring _____ 1-pair + Common/shield

RS-485 EOL Resistor _____ Built-in

RS-485 Baud Rates _____ 9600, 19 200, 38 400, or 76 800 bps

RS-485 Addressing _____ Controller's Web Configuration Interface

Modbus TCP _____ Devices must be on the same subnet

Supported Wireless Connectivity:

Wireless Adapter _____ Optional, USB Port Connection

Wi-Fi Communication Protocol _____ IEEE 802.11b/g/n and 802.11s

Wi-Fi Network Types _____ Client, Access Point, Hotspot

Supported Smart Room Control Components¹

Maximum number of supported devices per controller combined _____ 12

Allure EC-Smart-View Series _____ Up to 12¹

Allure EC-Smart-Comfort Series _____ Up to 6

Allure EC-Smart-Air Series _____ Up to 6¹

EC-Multi Sensor _____ Up to 4

ECx-Light-4 / ECx-Light-4D / ECx-Light-DALI _____ Up to 4

ECx-Blind-4 / ECx-Blind-4LV _____ Up to 4

1. For more details about supported quantities, see the **ECLYPSE Selection Tool.xlsx** spreadsheet file available for download from SmartSource.

2. A controller can support a maximum of 2 Allure sensor models equipped with a CO₂ sensor. Any remaining connected sensors must be without a CO₂ sensor.

Hardware

Processor _____ Sitara ARM processor

CPU Speed _____ 1GHz

Memory _____ 4GB Non-volatile Flash (applications & storage)
512MB RAM



- Real Time Clock (RTC) ————— Real Time Clock with rechargeable battery
Supports SNTP network time synchronization
- RTC Battery ————— 20 hours charge time, 20 days discharge time
Up to 500 charge / discharge cycles
- Cryptographic Module ————— FIPS 140-2 Level 1 Compliant
- Communications Ports:
 - Ethernet ————— 2 switched RJ-45 Ethernet ports
Supported Protocols ————— BACnet/IP, Modbus TCP, NTP, and REST
 - USB Connections ————— 2 × USB 2.0 Ports
1 × Micro-USB 2.0 Ports
 - RS-485 Serial Communications ————— Screw terminals
Supported Protocols ————— BACnet MS/TP or Modbus RTU
 - Subnet ————— RJ-45
- Status Indicators ————— Green LED: Power status, Subnet TX, RS-485 TX, and Ethernet Traffic
Orange LED: Controller status, Subnet RX, RS-485 RX, and Ethernet Speed

Mechanical

Dimensions (H × W × D) ————— 4.74 × 3.57 × 2.31" (120.31 × 90.67 × 58.56mm)

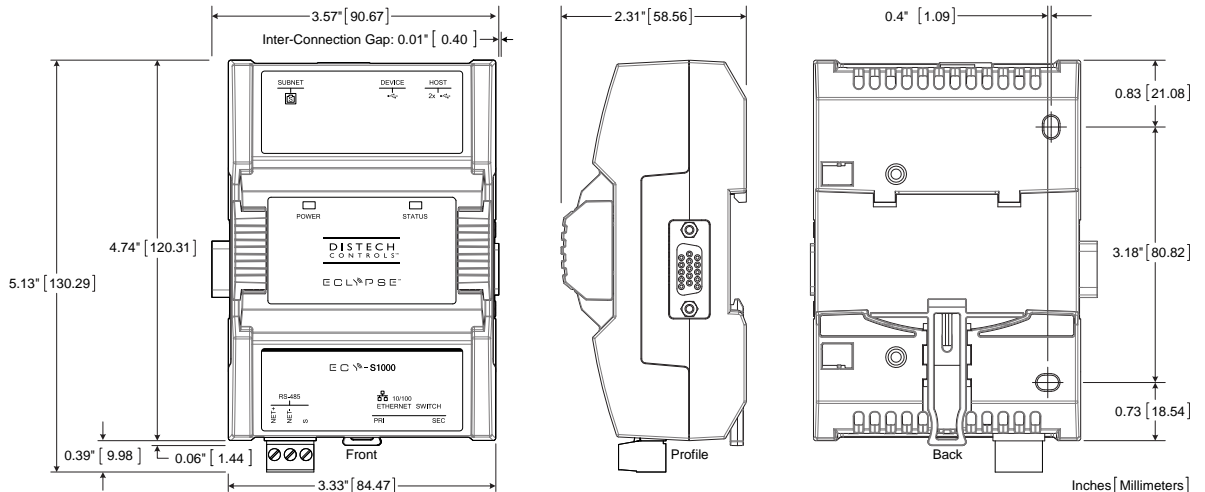

- Shipping weight ————— 0.85lbs (0.39kg)
- Mounting ————— DIN rail or screw mounting
- Enclosure Material ————— FR/ABS
- Enclosure Rating¹ ————— Plastic housing, UL94-V0 flammability rating
Plenum rating per UL1995

1. All materials and manufacturing processes comply with the RoHS directive and are marked according to the Waste Electrical and Electronic Equipment (WEEE) directive

Environmental

- Operating Temperature ————— 32 to 122°F (0 to 50°C)
- Storage Temperature ————— -22 to 158°F (-30 to 70°C)
- Relative Humidity ————— 0 to 90% non-condensing
- Ingress Protection Rating ————— IP20
- Nema Rating ————— 1

Standards and Regulations

CE:

- Emission ————— EN61000-6-3: 2007+A1:2011; Generic standards for residential, commercial and light-industrial environments
- Immunity ————— EN61000-6-1: 2007; Generic standards for residential, commercial and light-industrial environments

FCC ————— This device complies with FCC rules part 15, subpart B, class B

UL Listed (CDN & US) ————— UL916 Energy management equipment



I/O Modules

Power Supply Input

Voltage ————— 18VDC

Power Consumption ——— Calculate power supply requirements with the ECLYPSE Selection Tool

Hardware

Status Indicator ————— Green LEDs: inputs and outputs

For ECY-8UI, ECY-16DI, ECY-6UO, ECY-6UO-HOA, ECY-4UI4UO, ECY-4UI4UO-HOA, ECY-8UI6UO, ECY-8UI6UO-HOA, ECY-8UI6DOT, & ECY-8UI6DOT-HOA Models:

Mechanical

Dimensions (H × W × D) ————— 4.74 × 3.20 × 2.31" (120.31 × 81.17 × 58.56mm)

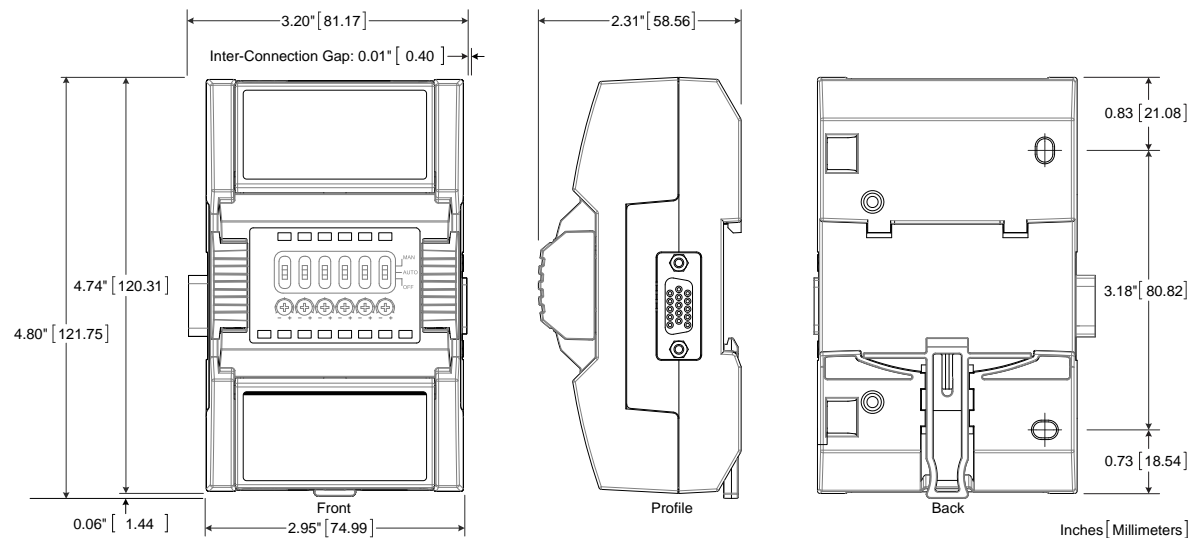

Shipping weight ————— 0.85lbs (0.39kg)

Mounting ————— DIN rail or screw mounting

Hot-swappable ————— Yes

Enclosure Material ————— FR/ABS

Enclosure Rating¹ ————— Plastic housing, UL94-V0 flammability rating; Plenum rating per UL1995

1. All materials and manufacturing processes comply with the RoHS directive and are marked according to the Waste Electrical and Electronic Equipment (WEEE) directive



Environmental

Operating Temperature _____ 32 to 122°F (0 to 50°C)

Storage Temperature _____ -22 to 158°F (-30 to 70°C)

Relative Humidity _____ 0 to 90% non-condensing

Ingress Protection Rating _____ IP20

Nema Rating _____ 1

Standards and Regulations

CE:

Emission _____ EN61000-6-3: 2007; A1:2011; Generic standards for residential, commercial and light-industrial environments

Immunity _____ EN61000-6-1: 2007; Generic standards for residential, commercial and light-industrial environments

FCC _____ This device complies with FCC rules part 15, subpart B, class B

UL Listed (CDN & US) _____ UL916 Energy management equipment



I/O Modules - Universal Inputs (UI)

General

Input Type _____ Universal; software configurable

Current Input Option Selection _____ DIP switch

Input Resolution _____ 16-bit analog to digital converter

Power Supply Output _____ 18VDC; 20mA maximum per 0 to 20 mA input

Contact

Type _____ Dry contact

Counter

Type _____ Dry contact

Maximum Frequency _____ 1Hz maximum,

Minimum Duty Cycle _____ 500milliseconds On / 500milliseconds Off

0 to 10VDC

Range _____ 0 to 10VDC (40kΩ input impedance)

0 to 5VDC

Range _____ 0 to 5VDC (high input impedance)

0 to 20mA

Range _____ 0 to 20mA

249Ω DIP-switch configurable internal resistor

Resistance/Thermistor

Range _____ 0 to 350 KΩ

Supported Thermistor Types _____ Any that operate in this range

Pre-configured Temperature Sensor Types:



14 / 18

ECLYPSE™ Connected System Controller

- Thermistor ————— 10K Ω Type 2, 3 (10K Ω @ 77°F; 25°C)
- Platinum ————— Pt1000 (1K Ω @ 32°F; 0°C)
- Nickel ————— RTD Ni1000 (1K Ω @ 32°F; 0°C)
- RTD Ni1000 (1K Ω @ 69.8°F; 21°C)

I/O Modules - Digital Inputs (DI)

General

Input Type ————— Dry contact or Open-Collector

Low Threshold ————— < 2.5V

High Threshold ————— > 3.0V

Pulse/Counter

Pulse Input ————— S0 output compatible

Maximum Frequency ————— 120Hz

Minimum Duty Cycle ————— 4.167milliseconds On / 4.167milliseconds Off

I/O Modules - Universal Outputs (UO)

General

Output Type ————— Universal; software configurable

Output Resolution ————— 10-bit digital to analog Converter

Output Protection ————— Built-in snubbing diode to protect against back-EMF,
for example when used with a 12VDC relay

Load Resistance ————— Minimum 200 Ω for 0 to 10VDC and 0 to 12VDC outputs
Maximum 500 Ω for 0 to 20mA output

Auto-reset Fuse ————— 60mA @ 140°F; 60°C

0 or 12VDC (On/Off)

Range ————— 0 or 12VDC

PWM

Range ————— Adjustable period from 2 to 65seconds

Floating

Minimum Pulse On/Off Time ————— 500milliseconds

Drive Time Period ————— Adjustable

0 to 10VDC

Range ————— 0 to 10VDC linear

0 to 20mA

Range ————— 0 to 20mA

Current Source ————— 20mA maximum per 0 to 20 mA output

Ports UO1, UO2, and UO3 only ————— DIP switch

HOA

Hand-Off-Auto switch ————— When equipped

Supervision allows control logic to read the current

Threshold _____ HOA switch and potentiometer settings
Configurable
Potentiometer Voltage Range _____ 0 to 12VDC

I/O Modules - Digital Output (DOT)

General

Output Type _____ 24VAC Triac; software configurable
Maximum Current _____ 0.5A continuous
1A @ 15% duty cycle for a 10 minute period
Power Source _____ External power supply

0 or 24VAC (On/Off)

Range _____ 0 or 24VAC

PWM

Range _____ Adjustable period from 2 to 65seconds

Floating

Minimum Pulse On/Off Time _____ 500milliseconds
Drive Time Period _____ Adjustable

HOA

Hand-Off-Auto switch _____ When equipped
Supervision allows control logic to read the current HOA switch setting

I/O Modules - Digital Output (DOR)

For ECY-8DOR & ECY-8DOR-HOA Models:

General

Output Type _____ Relay contact
Relay Type _____ Form C
Power Source _____ Dry contact (external power supply)
Operating Voltage _____ 0 to 277VAC or 0-30VDC ±10%, see HIG for mounting specifications

Maximum Current

- Resistive Load _____ 10A
- Inductive Load _____ 6A
- Motor Load _____ 3A

Protection _____ Outputs must be protected with max 10 A external circuit breaker

Digital

Range _____ On/Off

HOA

Hand-Off-Auto switch _____ When equipped
Supervision allows control logic to read the current HOA switch setting

Mechanical

Dimensions (H × W × D) ————— 4.74 × 5.15 × 2.31" (120.31 × 130.07 × 58.56mm)

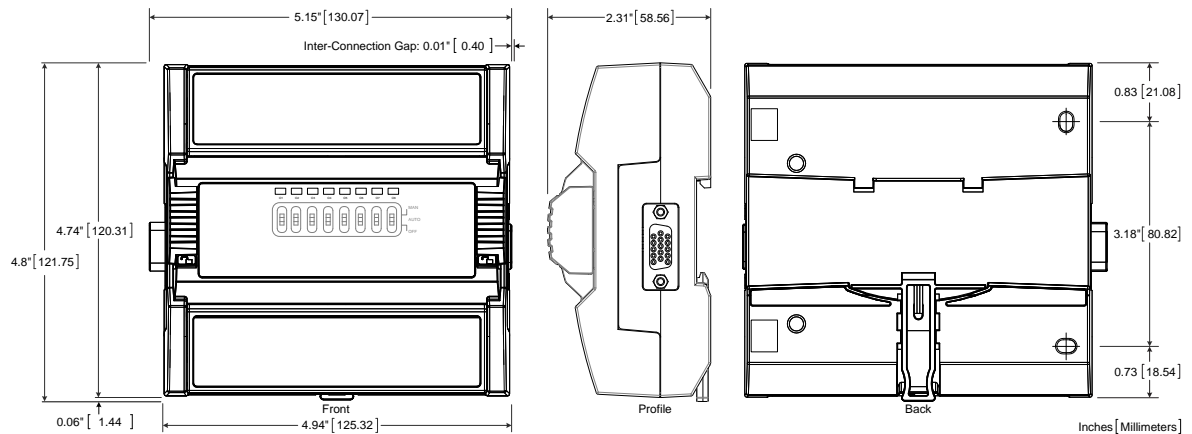

Shipping weight ————— 0.75lbs (0.34kg)

Mounting ————— DIN rail or screw mounting

Hot-swappable ————— Yes (once high voltages have been removed)

Enclosure Material ————— FR/ABS

Enclosure Rating¹ ————— Plastic housing, UL94-5VB flammability rating

1. All materials and manufacturing processes comply with the RoHS directive and are marked according to the Waste Electrical and Electronic Equipment (WEEE) directive

Environmental

Operating Temperature ————— 32 to 122°F (0 to 50°C)

Storage Temperature ————— -22 to 158°F (-30 to 70°C)

Relative Humidity ————— 0 to 90% non-condensing

Altitude ————— <6562ft (2000m)

Pollution Degree ————— 2

Ingress Protection Rating ————— IP20

(must be mounted in a protective enclosure to conform with electrical installation standards)

Overtoltage ————— Category II - 2.5 kV

Standards and Regulations

CE:

Electrical Safety ————— EN 60730-1 : 2011 - Automatic electrical controls for household and similar use - Part 1: General requirements

Emission ————— EN61000-6-3: 2007; A1:2011; Generic standards for residential, commercial and light-industrial environments

Immunity ————— EN61000-6-1: 2007; Generic standards for residential, commercial and light-industrial environments

UL Listed (CDN & US) ————— UL 61010-1 Safety Requirements For Electrical Equipment For Measurement, Control, And Laboratory Use - Part 1: General Requirements - Edition 2 - Revision Date 2008/10/28

FCC ————— This device complies with FCC rules part 15, subpart B, class B



Specifications subject to change without notice.

ECLYPSE, Distech Controls, the Distech Controls logo, EC-Net, Allure, and Allure UNITOUCH are trademarks of Distech Controls Inc. BACnet is a registered trademark of ASHRAE; BTL is a registered trademark of the BACnet Manufacturers Association. All other trademarks are property of their respective owner. The Bluetooth® word mark and logos are registered trademarks owned by Bluetooth SIG, Inc. and any use of such marks is under license. All other trademarks are property of their respective owners.

©, Distech Controls Inc., 2015 - 2018. All rights reserved.

